



MICHELIN LE MANS CUP COMMITTEE



TO: Teams Manufacturers
CATEGORY: LMP3 LMP3 Pro/Am GT3

DECISION N°: MLMC_2025_D05_GT3_Technical_Information

DATE: 24/03/2025

FROM: The Michelin Le Mans Cup Committee

SUBJECT: Electronic equipment

APPLICABLE REGULATION

- 2025 Michelin Le Mans Cup Sporting Regulations
- 2025 Technical Regulations for GT3

DECISION

ELECTRONIC EQUIPMENT

The use of Marelli Telemetry System is mandatory for 2025 MLMC season.

The Telemetry System designed by Marelli is a “modular” system in which, on board the vehicle, the logging functionalities have been separated from the wireless functions.

The system is designed to log the data input from the mandatory sensors, some of which are directly connected to the logger. The data is then stored on the systems’ USB-flashdrive and must be uploaded each time a car enters the pitlane.

The integrated smart antenna also provides accurate live data transmitted via LTE. This allows the technical team to monitor mandatory sensor values while the car is running on track and review racing incidents and infringements with a minimum delay.

Furthermore, it connects the vehicle to race control, sending the GPS-position of the car to locate it on track and receiving flag signals to show on the marshalling display onboard the vehicle.

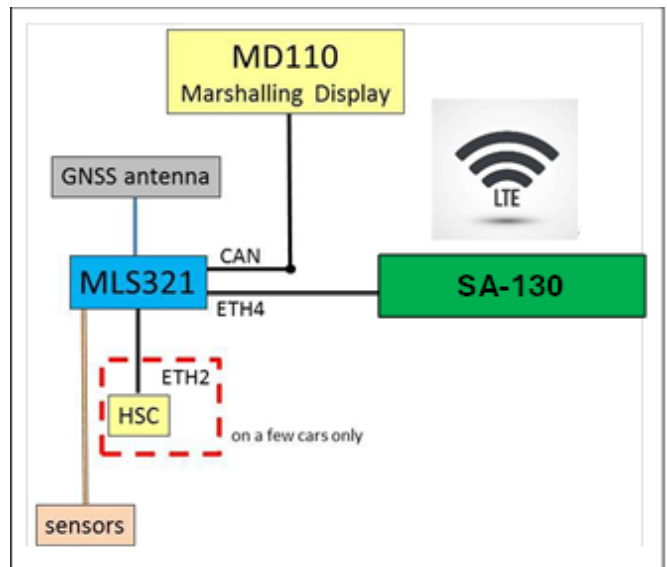

REAR WING ANGLE MEASUREMENT

Where a chassis reference plane is available inside the cockpit of the car the top surface of the plane shall remain unobstructed at all times to allow scrutineers to zero an inclinometer when carrying out rear wing angle measurements. The clearance volume above the plane shall be a minimum of 220mm long x 60mm wide x 65mm high.



MICHELIN LE MANS CUP COMMITTEE



ENGINE RESTRICTOR SIZES

To accommodate the BOP process requirements each team/matrix manufacturer shall ensure that the following size engine restrictors for their cars are available at all events:

	Restrictor diameter list (mm)					
Mercedes	33	34	34.5	35	36	
Porsche	36	37.5	38	39.5	40	41.5

PERIOD OF VALIDITY/APPLICATION OF THE DECISION

This decision comes into effect:

- with immediate application**
 from:

And is applicable:

- until further notice**
 for the mentioned Competition(s) only